

Power Supply Transmit/Receive AC Line Relay

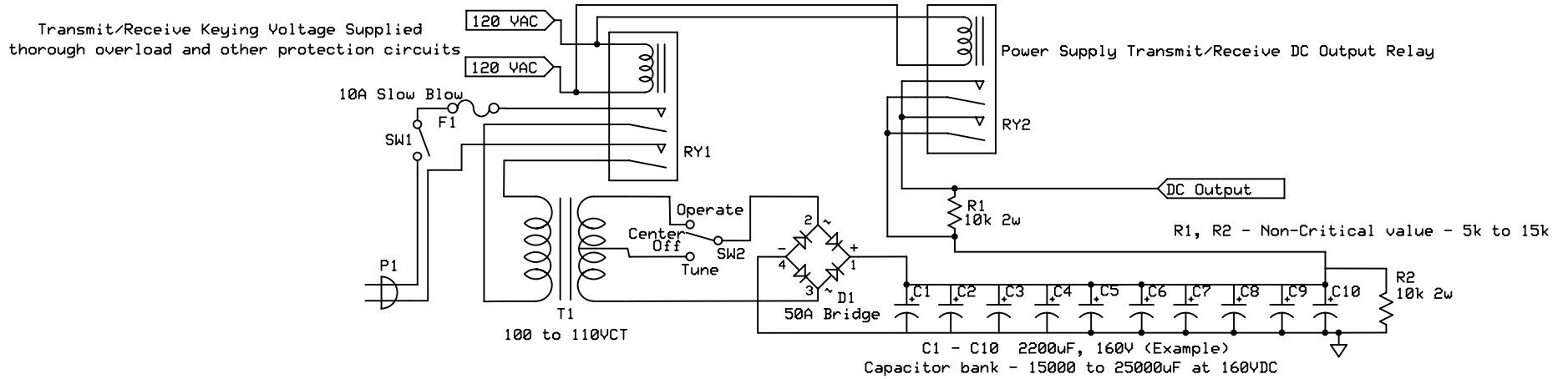

Power Supply DC output under load generally 1.25 X the RMS transformer secondary voltage under load.

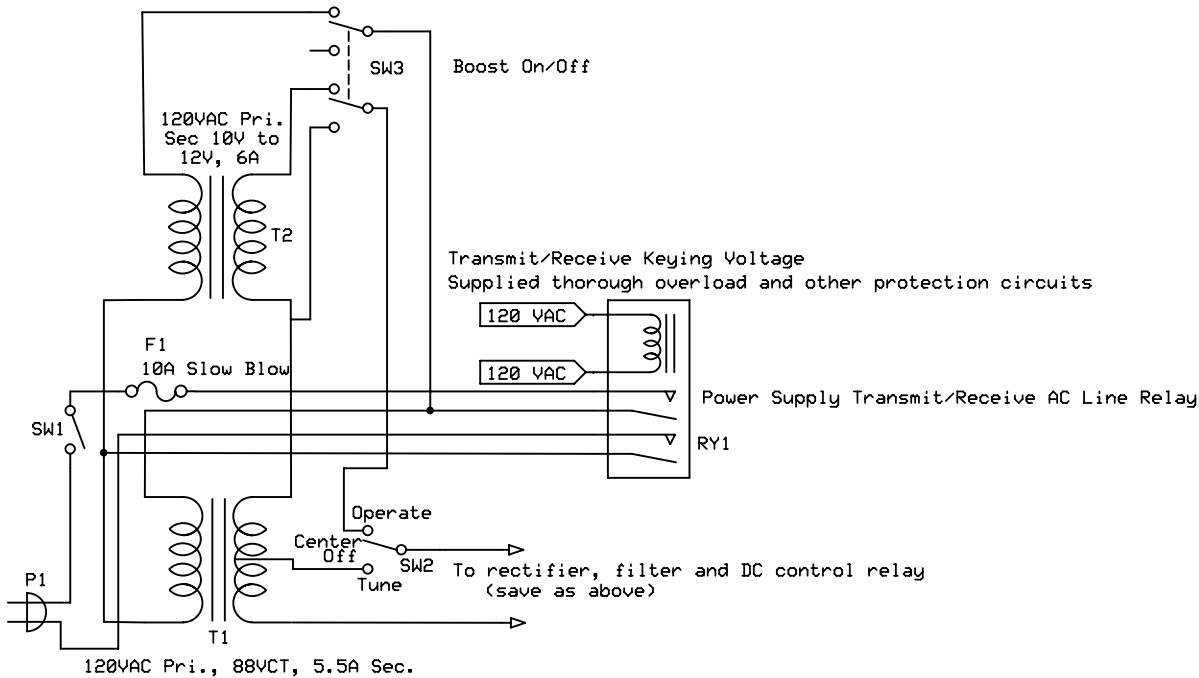

Power Supply example #2 shows connection of a "boost" transformer if the power transformer does not have sufficient secondary voltage. 88V transformer shown. Produced 45VDC output with boost on.

Radio Engineering Associates

Power Supply for PWM

S. Cloutier

Rev E
09/2010

WA1QIX